

# Landing gear Modul

The Modul series of telescopic landing gear is extremely versatile. Thanks to its modular construction with variable mounting and operating heights, various crank handles and connection shaft lengths, plus five different foot types, all client requirements can be catered to.

Modul B is the tried-and-tested standard telescopic landing gear. The Modul C range consists of various landing gears which are designed for special applications.

Both ranges offer practical product advantages: the integrated gearbox has optimum protection, and requires minimum force to be applied on the crank handle in both directions. At the same time, Modul offers an extraordinary increase in lift of up to 120 mm combined with smaller dimensions for fitting. It goes without saying that the telescopic landing gear is extremely sturdy and complies with the strict AAR standard.

The support is not a standalone, functional device. It is designed to be mounted on a trailer. The vehicle may not be operated until it has been ensured that the towed vehicle with the support complies with the applicable national road traffic regulations. In Germany, the relevant "TÜV" Safety Regulations and "StVZO" Motor Vehicle Safety Standards are to be observed. The telescopic landing gear is always to be used in conjunction with the instructions for use issued by the manufacturer of the relevant trailer.

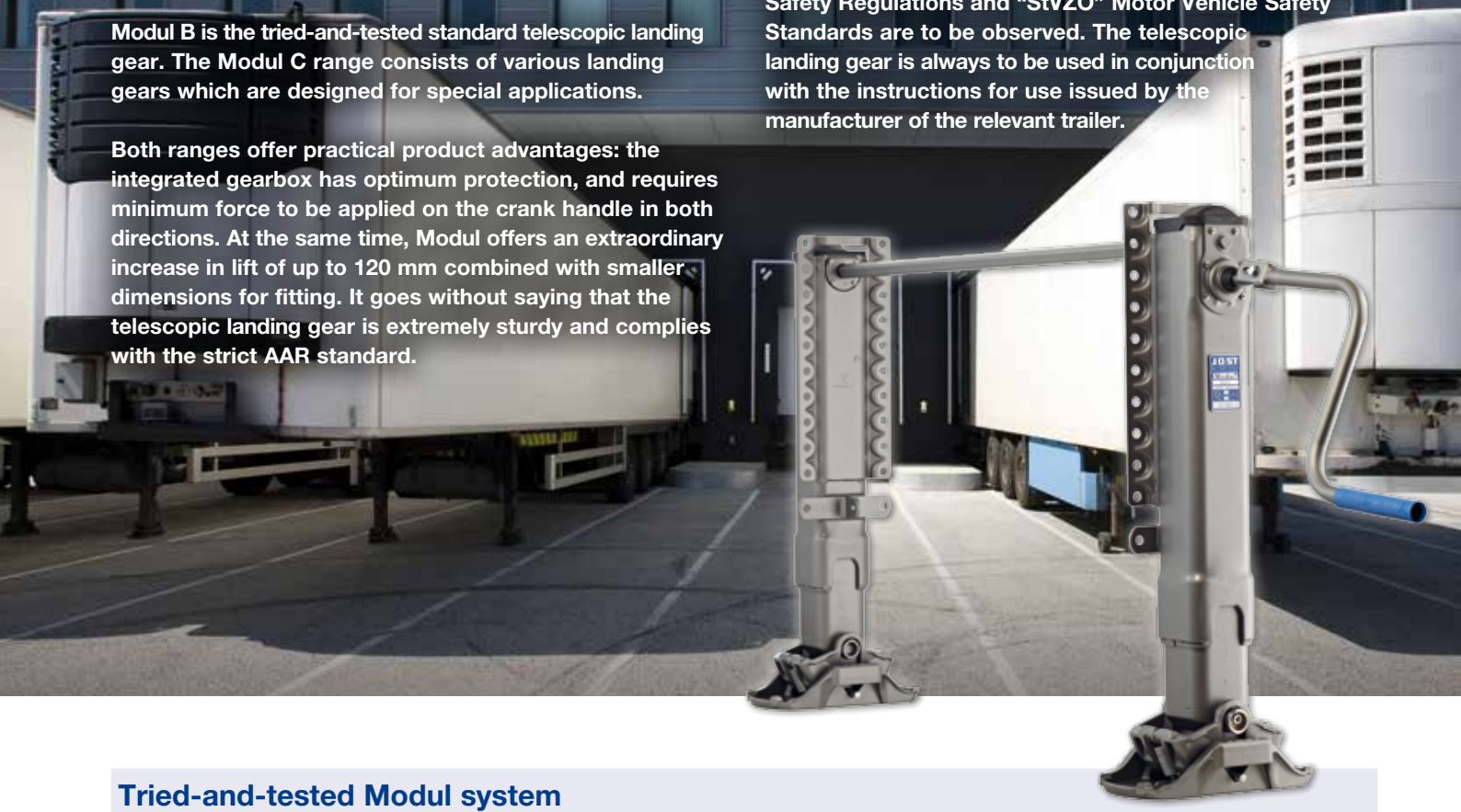

## Tried-and-tested Modul system



Since the market entrance Modul landing gears are setting benchmarks. The modular construction allows a multitude of different varieties.

- Easy to assemble and replace foot system
- Greatest flexibility of installation thanks to a range of back plates and only a slight overhang above the connection shaft
- Various crank handles and connection shaft lengths
- Significant gain in lifting force compared to comparable products
- Attractive design
- For universal application
- Type reduction thanks to modular system guarantees high level of flexibility in spare parts business

## Patented Modul drive

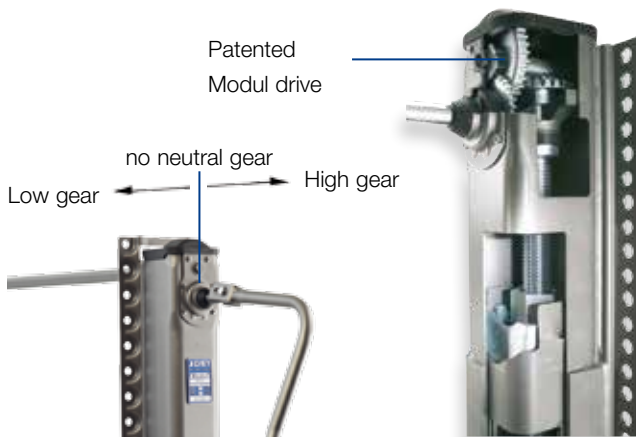

The patented drive is perfectly protected by the internal construction. In addition it offers various advantages in daily use:

- Easy to change between high and low gears
- Very compact construction with high efficiency and extremely low wear
- Large lifting force per turn of the crank with low crank force allows easy and convenient operation
- Reliably secured against run-down
- Maintenance-free

## Support feet

The Modul series of telescopic landing gear are available with a range of different feet: S, A, T and TC foot.



Foot-S  
(Standard)



Foot-A  
(Rocking foot)



Foot-TC  
(Flat sand shoe)



Foot-T  
(Sand shoe)

## Additional advantages

### Outstanding corrosion protection

Landing gears from JOST are especially sturdy and resist also unfavorable exterior conditions.

- Careful pre-treatment
- Premium surface through powder coating
- Long-lasting protection against environmental influences and stone chips

### Easy maintenance

The Modul landing gears are equipped with a long-term lubrication. Therefore they can be used three years without relubrication.

- Long-lasting, maintenance-free drive
- No need for subsequent lubrication of our premium stabilisation and aluminium telescopic landing gears with lubrication tube



Lubrication tube

### Tested and developed according to internationally recognized standards

- Regular inspection during series production based on the strict AAR standard
- Quality management in accordance with ISO/TS 16949
- Environmental management in accordance with ISO 14001
- **3 year guarantee**

### Top service

Locations worldwide and a broad network of dealer ensure professional advice.

- Competent and individual advice from Sales and Customer Service
- Support for our customers using CAD data during the planning phase
- High level of prevalence and global spare parts supply with short delivery times
- Easy to repair, such as using our foot replacement system



## The perfect landing gear for every application

### Telescopic landing gears

Page

#### Modul B – Standard

- Tried-and-tested standard telescopic landing gear
- The modular construction allows a multitude of different varieties



134

#### Electric landing gear Modul E-Drive

- Electric raising and lowering of the landing gear
- Simple operation at the push of a button
- Highly useful for limited accessibility and confined spaces and for frequent coupling and decoupling
- Based on the highly reliable and robust Modul series



138

#### Aluminium landing gear Modul CA

- Weight-optimised
- Premium telescopic landing gears in an aluminium design
- Greatest possible weight advantage for telescopic landing gears
- Thus ideally suited to tank and silo vehicles



141

#### Special telescopic landing gears Modul C

- Modul C special telescopic landing gears for special applications
- Especially compact telescopic landing gears with large ground clearance
- Drawbar landing gears with pivot bearings for use in combination with central axle trailers and dollies
- Especially robust telescopic landing gears for heavy duty applications
- Telescopic landing gear with low-lying connection shaft, especially for tank and silo trailers
- Stabilisation landing gear for rear support and level regulation.



144

#### Drop leg FS 075

- Ideal for applications that require low weight and where uncoupling is rarely needed.



189

### Options

#### Two-sided operation

All telescopic landing gears in our Modul series which are used in a set with a connection shaft are also available with two-sided operation with a special crank. Operation by two people reduces the manual force required to 110 N (at 16t lifting capacity) – operation by a single person from the right or left is also possible.

## Crank handles

Various crank handle lengths for individual adjustment to the vehicle width.

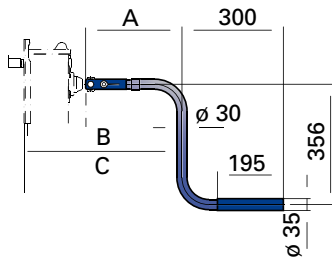

Order No.	A	B (Low gear)	C (High gear)
JS U01	350	534	553
JS U02	415	599	618
JS U03	450	634	653
JS U04	480	664	683
JS U05	520	704	723
JS U07	570	754	773
JS U08	620	804	823

## Connection shaft

Order No.	E (Length of connection shaft)
JS L01	1340
JS L02	1450
JS L03	1470
JS L04	1500
JS L05	1505
JS L06	1575
JS L07	1605
JS L08	1635
JS L09	1700
JS L10	1790

## Crank extension

**JS E030.001 and JS E030.007:** The crank extension support is welded to the semi-trailer chassis.

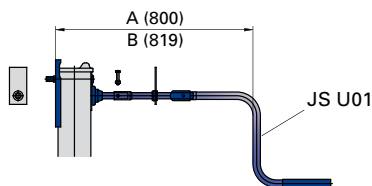

**JS E030.004:** The exterior chassis control is bolted to the landing gear. Assembly only possible with back plate above (01) or double back plate (03).

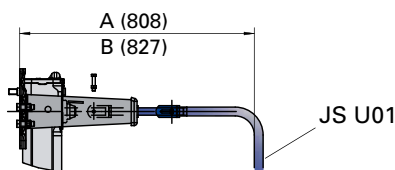

Order No.	A (Low gear)	B (High gear)	Operation
JS E030.001	800	819	one-sided
JS E030.004	808	827	one-sided
JS E030.007	800	819	two-sided

## Mounting kits for bracing

The shear and transverse forces that occur mean that bracing is required for the landing gear.

Mounting kit (without bracing):

Order No.	Description
JS E020.001	Mounting kit, standard (28 bolts and nuts)
JS E020.002	Mounting kit, double plate (48 bolts and nuts)
JS E020.003	Mounting plate for tandem trailer (s. Fic. p. 156)

The following illustration shows an example of bracing:

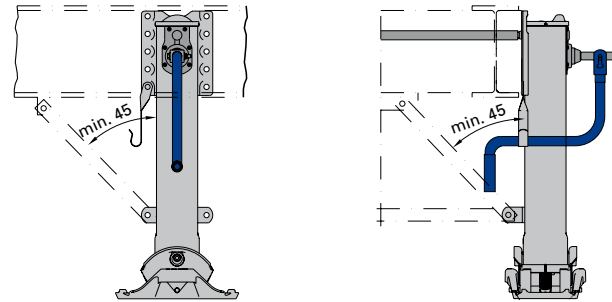

## Accessories

Bolt-on brackets for individual adjustment.

Order No.	Description
JS E010.001	Bolt-on bracket, loose
JS E010.002	Clamp for bolt-on bracket
JS E020.004	Nut and bolt for clamp

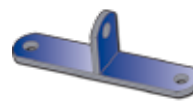

JS E010.001

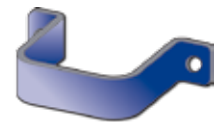

JS E010.002

Lubricating nipple for lubricating spindles and spindle nuts.

Order No.	Description
JS E008.4000	Grease nipple

## General technical data for landing gear

Lift by one turn of the crank (mm)	
Low gear	0,9
High gear	15,0

Landing gear (per kit) (t)	
Lifting capacity	24
Static test load	50

Static test load:

Load (t)	Crank force
16	210 N

